



***HOTFOIL-EHS “HB” MODULE HEATING SYSTEM
INSTALLATION, OPERATION & MAINTENANCE MANUAL
HB.IOM.R4***

**Hotfoil-EHS, Inc.
2960 East State Street Extension
Hamilton, NJ 08619
Phone # (609) 588-0900
Fax # (609) 588-8333
www.hotfoilehs.com**

INDEX

<i>I</i>	<i>Product Specification</i>
<i>II</i>	<i>Storage Instructions</i>
<i>III</i>	<i>Inspection</i>
<i>IV</i>	<i>Installation of HB Heating Module</i> <i>Drawing #D-1275 Rev 4</i> <i>Drawing #C-1192 Rev 2</i>
<i>V</i>	<i>Installation of Flexible</i> <i>Heaters: Throat, Poke Tube, Manway, etc.</i>
<i>VI</i>	<i>Thermostat Bulb Sensor Installation</i> <i>Drawing #B-1504 Rev 0</i> <i>T/C - RTD Sensor Installation</i> <i>Drawing #B-5912 Rev 0</i>
<i>VII</i>	<i>Operating Instructions</i>
<i>VIII</i>	<i>Maintenance Instructions</i>
<i>IX</i>	<i>Heater Dry Out Procedure</i>
<i>X</i>	<i>Suggested Method of Routing</i> <i>Cold Leads</i> <i>Drawing #A-1073 Rev 0</i>

I - PRODUCT SPECIFICATION

<i>Model</i>	<i>Hotfoil Type HB Heating Module</i>
<i>Construction</i>	
<i>Heating Element</i>	Patented nichrome flat foil heating elements sewn into high temperature fiberglass cloth
<i>Insulation</i>	1-3/16" thick mineral wool
<i>Heater Face</i>	Siliconized fiberglass cloth
<i>Dielectric Material</i>	Multi-layer fiberglass cloth construction
<i>Heater Casing</i>	Aluminum – Copper free
<i>Cold Leads</i>	Two conductor cable, nickel plated copper, #16 AWG double fiberglass insulated conductors, Siliconized in extruded sheath of silicone rubber

Total construction is modularized for ease of handling and installation.

II - STORAGE INSTRUCTIONS

Introduction:

The type HB heating module is an electrical resistance type heater designed for operating voltages up to 600 VAC.

As with all electric items the units should be stored in dry areas, indoors

The following storage procedure is recommended:

- 1) Store all heating modules indoors, unopened, and in their original shipping crates until ready for installation.
- 2) Do not store modules directly on concrete, cement or earth floors.
- 3) Store modules on pallets or shelves.
- 4) Heaters should be stored and kept in dry environments only.
- 5) Shipping crates should be handled with care. Damage to the shipping crate caused by dropping, fork lift arms or abuse of any description should be investigated prior to installation of the modules.
- 6) Refer to Section on “Heater Dry Out Procedure” section IX to address heaters that have been exposed to moisture.

III - INSPECTION

All heaters are 100% inspected and tested before shipment. However, to ensure minimum delay in scheduling and heating system integrity, all heaters should be inspected and tested at key milestones:

- 1) After delivery to job site.
- 2) Before and after installation on hoppers.
- 3) Before thermal insulation is applied over the heaters.
- 4) Before heating system start-up.
- 5) Periodically after heating system commissioning.

The extent of inspections should depend on the condition of heaters and packaging. However, in general the following should be performed at the above times:

- 1) Check outer packaging for signs of physical damage or exposure to water.
- 2) Check all heaters for identification markings.
- 3) Check all heaters for physical damage (cuts, bends, tears, etc.)
- 4) Check all heaters with ohmmeter for electrical continuity and correct DC resistance values between the cold leads (refer to job drawings). DC resistance values should be within +/- 10%.
- 5) Check all heaters with a 500 VDC megohm meter for sufficient insulation resistance between shorted cold leads and ground.

Minimum acceptable value is 50 megohms.

Reduced values may indicate excessive moisture present within the heater and should be dried out before installation (refer to Section on "Heater Dry Out Procedure").

NOTE: Do not install damaged heaters. If damaged, replace heating module complete with cold leads.

SECTION IV

THIS DRAWING AND ITS CONTENTS ARE THE EXCLUSIVE PROPERTY OF HOTFOIL, INC. AND NO REPRODUCTION, USE OR DISCLOSURE IS AUTHORIZED WITHOUT WRITTEN CONSENT.

INSTALLATION INSTRUCTIONS FOR HB MODULE HEATING SYSTEMS (Using Heater Templates)

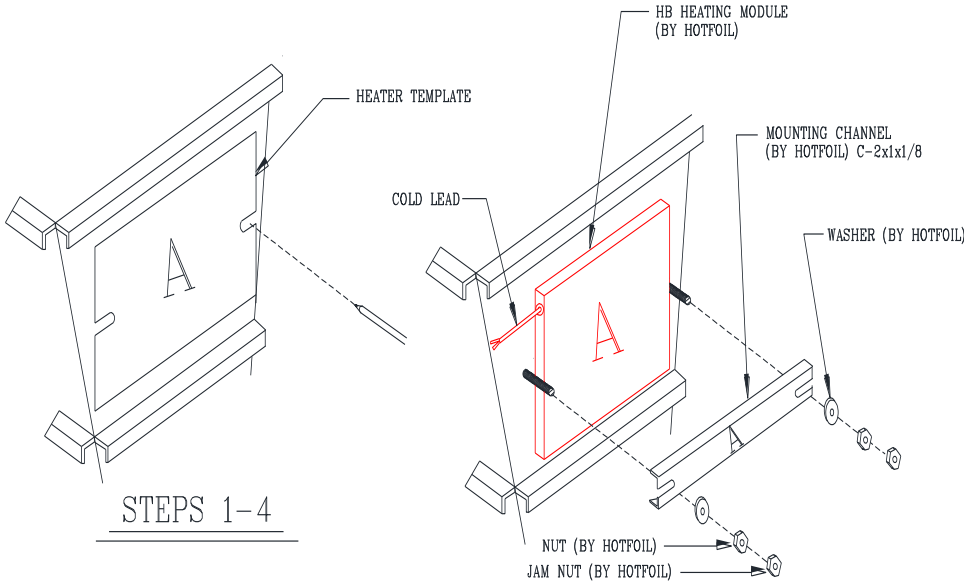

STEPS 1-4

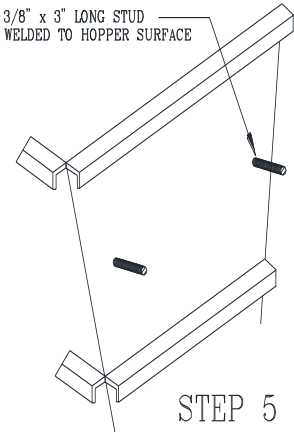

STEP 5

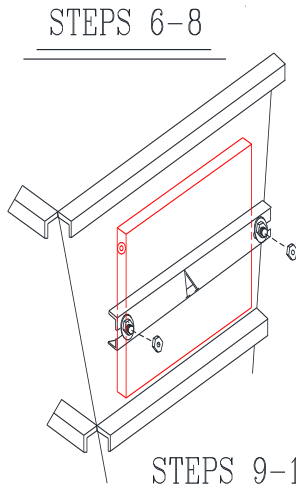

STEPS 6-8

STEPS 9-10

CAUTION NOTES:

- 1) All HB module heating systems are usually packed by "sets" (one "set" per hopper) therefore, unpack and install one heater "set" at a time.
- 2) Do not grind, weld or flame cut near the installed heaters. Remove the heater first.
- 3) Heaters must be kept dry, therefore thermally insulate and/or protect the heaters from weather or water right after installation.
- 4) Perform a heating system inspection and the necessary electrical tests before thermally insulating. (Refer to Hotfoil's IOM manual for HB Modules).
- 5) It is the responsibility of the user/client to ensure that the entire heater installation is in compliance with all the applicable federal, state and local electrical codes and regulations.

- 1) Refer to pertinent job drawings which show the heater layout to identify hopper sides and terminal/junction box location at the hopper corner.
- Note: On some jobs, hopper sides may be different from hopper to hopper, therefore, identify hopper side reference by their protrusions.
- 2) Mount the terminal/junction box in the designated location but within 2 feet of the hopper/cold lead exit point otherwise heater leads may not reach the junction box. (Refer to the job drawings).
- 3) Starting near this hopper corner, use the HB Heating Module template with the same letter reference for locating the heaters on the hopper sides.
- 4) Locate the templates as per the job drawings, i.e. center them and locate as low as possible.

NOTE: IN confined or restricted access areas, the actual Module can be used as the template.

- 5) Mark the "inside areas" of the template slot cutout.
 - 6) Weld the studs on the marked areas.
- Notes: - Check each stud for good, solid attachment to the hopper plate.
 - Ensure that the weld around the base of the stud will not interfere with the heater.
 - Studs used should be 3/8 inch by 3 inches long and fully threaded.
 - ensure that the hopper plate where the heaters are to be located is free from grease, dirt, welds, weld spatter or other sharp protrusions & irregularities. Grind the surface if necessary.

- 7) Place the correct HB Heating Module between the studs.
- 8) Place the mounting channels with the same letter reference as the heater over the studs and across the metal surface of the heating module.
- 9) Place a washer (1 inch outside diameter) and a nut on each stud.
- 10) Tighten the nut with a wrench until heater is in good, tight contact with the hopper plate without distorting the mounting channel web - recommended torque is 50 INCH-POUNDS.
- 11) Use a second nut to jam the first one in place.
- 12) When all the heaters are installed, route the cold leads across the adjacent hopper side and then up or down the hopper corner to the "cold lead exit point" and into the junction box.
 Note: This procedure may be reversed to use up the LEAST amount of cold lead.
 Note: Cold lead should be routed along hopper walls only, never across heaters.
- 13) Use round edged bushings, insulation pins, or other high temperature materials (like glass adhesive tape) to immobilize and protect the cold leads from sharp edges, corners, etc., which may damage the leads.
 Notes: Use flexible or rigid conduit to protect the cold leads where they exit the hopper's thermal insulation and enter the junction box. (Flexible conduit should be used wherever cold lead protection is required or desirable).
- 14) Interconnect all the heater cold leads on the terminal blocks inside the terminal/junction box as per the job drawings.

- Notes: - some heaters may need to be interconnected in a "series circuit" therefore always refer to the job drawings.
 - Do no wire or operate "incomplete" heater series circuits.
 - Retain the heater wire markers on the cold leads (or mark as required) for future identification.
- 15) Locate the temperature sensors exactly, as per the job drawings.
 Note: Temperature control sensor should be securely attached to the hopper plate whose temperature it is to measure. (Use recommended methods only).

4	NOTES REVISED	JOD	6/13/17	SCALE	N.T.S	hotfoil Electric Heat Tracing	HOTFOIL, INC. ROSELAND, NEW JERSEY
3	NOTES REVISED	MJR	9/16/06	BY	JMP		
2	DRAWN ON CAD	MJR	2/11/98	DRAWN	FM	5/2/98	
1	REVISED NOTES	GH	6/16/88	CHECKED	MM	6/16/88	
REV.	DESCRIPTION	DR.	DATE	APPROVED	DATE	DATE	

INSTALLATION OF
"HB" HEATING MODULE

DRAWING NO. D-1275

SECTION IV

THIS DRAWING AND ITS CONTENTS ARE THE EXCLUSIVE PROPERTY OF HOTFOIL, INC. AND NO REPRODUCTION, USE OR DISCLOSURE IS AUTHORIZED WITHOUT WRITTEN CONSENT.

NOTES:

- 1) To prevent convective heat losses to the top of the hopper cavity, Thermal Insulation convection stops should be installed.
- 2) These should be located all "AROUND" and "ON TOP" of the hopper stiffeners as shown opposite.
- 3) All "CONVECTION STOPS" should be of similar material and thickness as the rest of the hopper thermal insulation.
- 4) All "CONVECTION STOPS" should be packed and fit snugly so that no "GAPS" are created
- 5) A "DOUBLE LAYER" of thermal insulation must be installed around the hopper throat.
- 6) All hopper metal cladding should fit tightly around each hopper protrusion.
- 7) All metal cladding "GAPS" should be sealed with suitable sealer.
- 8) Minimum 2" air gaps are to be left behind heater modules. Heaters may be designed to allow for direct application of insulation - consult Hotfoil for any such application.

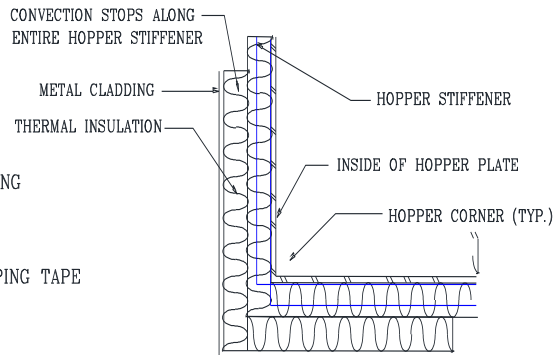
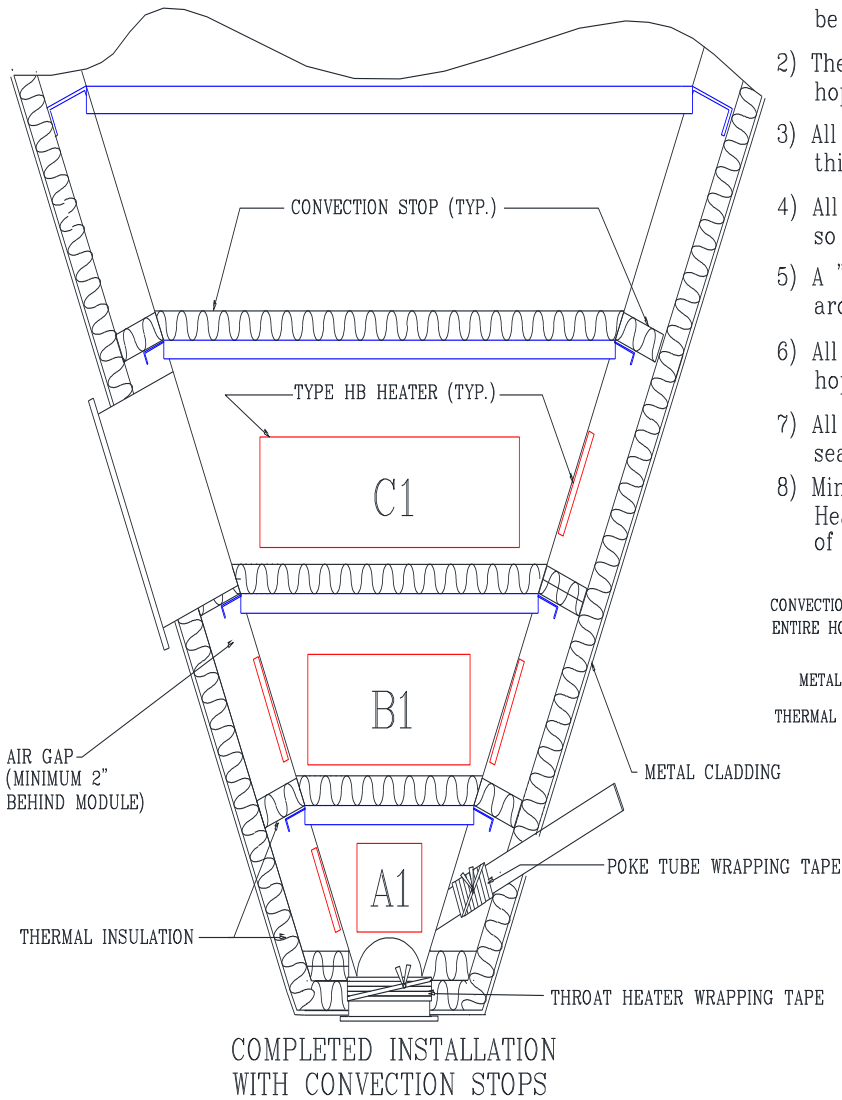

HOPPER CORNERS COMPLETELY BLOCKED WITH THERMAL INSULATION TO PREVENT "CONVECTIVE" HEAT LOSSES TO THE TOP OF THE HOPPER CAVITY

CORNER DETAIL

2	AIR GAP DETAILS	JOD	06/13/17	SCALE	N.T.S	 <small>Electric Heat Treating</small>	HOTFOIL, INC. MEMPHIS, TENN 38115
1	REVISED CONVECTION STOP INFORMATION	MJR	11/24/96	DRAWN	BY		DATE
REV.	DESCRIPTION	DR.	DATE	DATE	BY	DATE	DATE
				TYPICAL			DRAWING NO. C-1192
							PAGE 2

V - INSTALLATION INSTRUCTIONS FOR FLEXIBLE HEATERS
Hopper Throat Heater, Poke Tube Heater, Manway, etc.
Not used on all systems

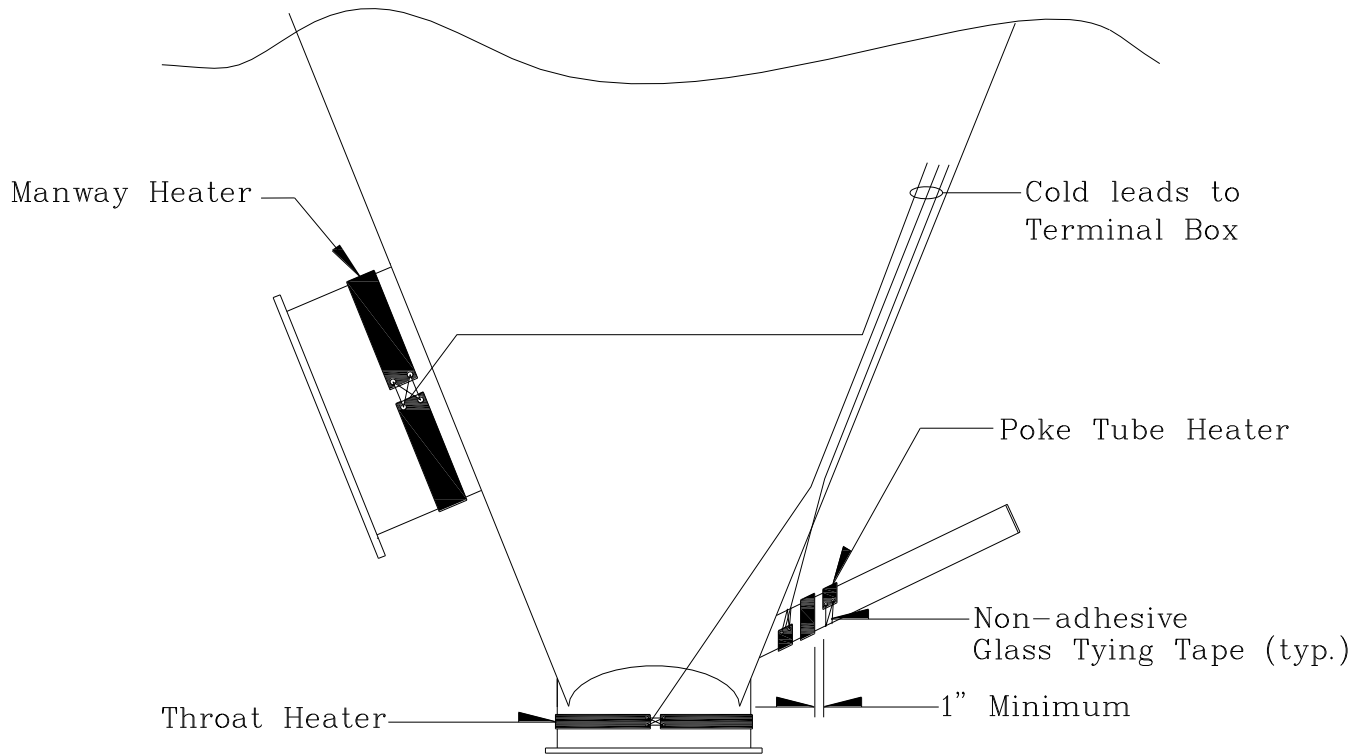

HEATER INSTALLATION

- 1) Inspect surface to be heated. Ensure it is clean and free from sharp welds, corners or weld spatter which may damage the heater. Grind surface smooth if required.
- 2) Locate flexible heater on the surface to be heated.
Note: Position the flexible heater such that it will not be cut by future thermal insulation metal cladding.
- 3) Heater cold leads should be routed along the hopper surface and approximately as shown on the job drawings to the termination box.
- 4) With sufficiently long non-adhesive fiberglass tying tape, secure one heater end to the other (or to the poke tube itself in case of poke tube heater).

Note:

- a) Ensure that the heater is smooth and tight around the surface to be heated.
- b) Use double looping tie knots to prevent non-adhesive fiberglass tape slippage.
- c) Never overlap the heater upon itself.

- 5) When several wraps of heater are applied, space the adjacent heater wraps approximately one inch apart.

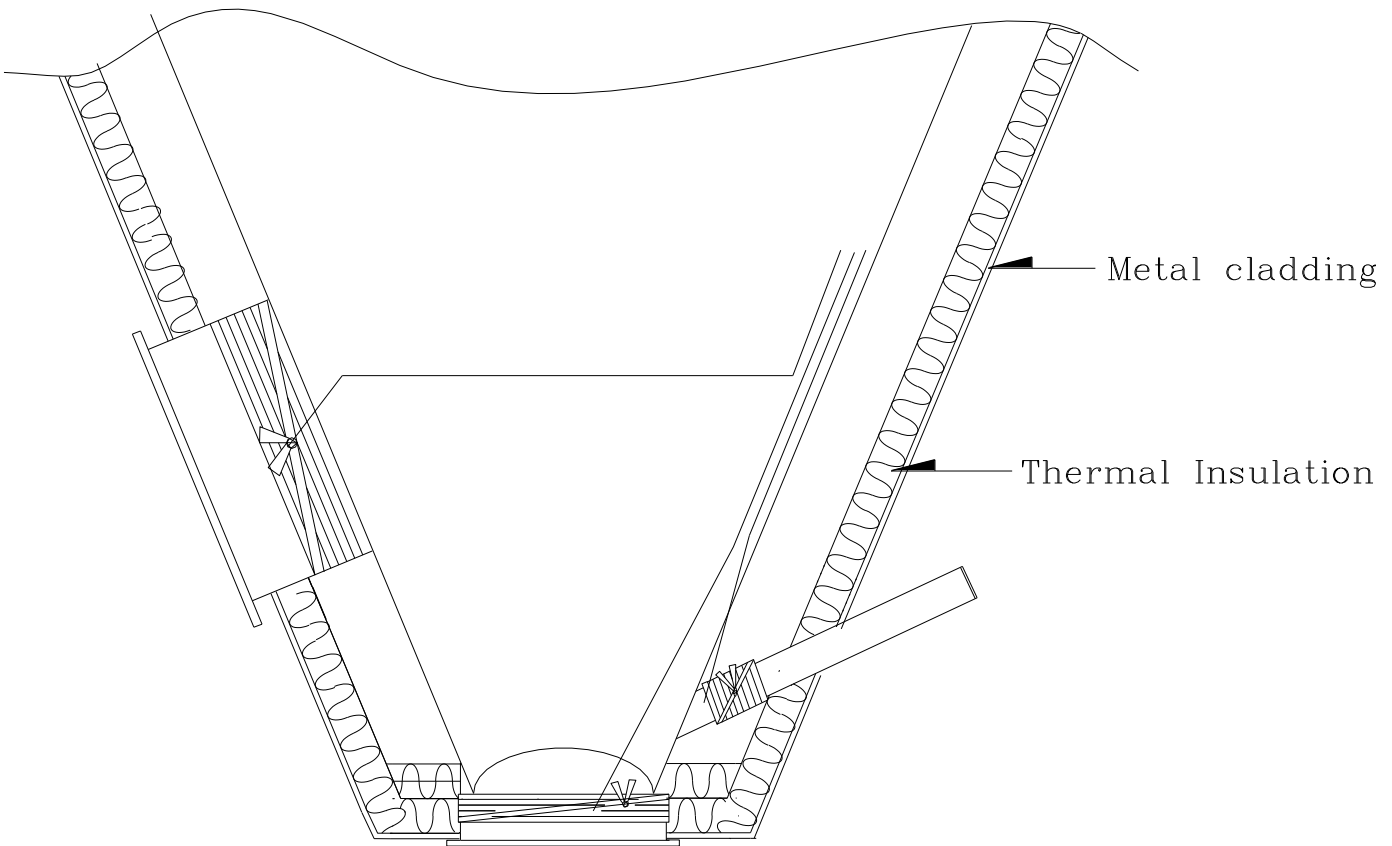

COMPLETED INSTALLATION

- 6) Wrap tightly entire flexible heater with more non-adhesive fiberglass tying tape overlapping slightly each successive wrap. Secure both ends by tying them together.

Note:

- a) Do not twist the fiberglass tape when wrapping.
- b) Keep the fiberglass tape dry since water may reduce its mechanical strength.

SECTION VI

THIS DRAWING AND ITS CONTENTS ARE THE EXCLUSIVE PROPERTY OF HOTFOIL, INC. AND NO REPRODUCTION, USE OR DISCLOSURE IS AUTHORIZED WITHOUT WRITTEN CONSENT.

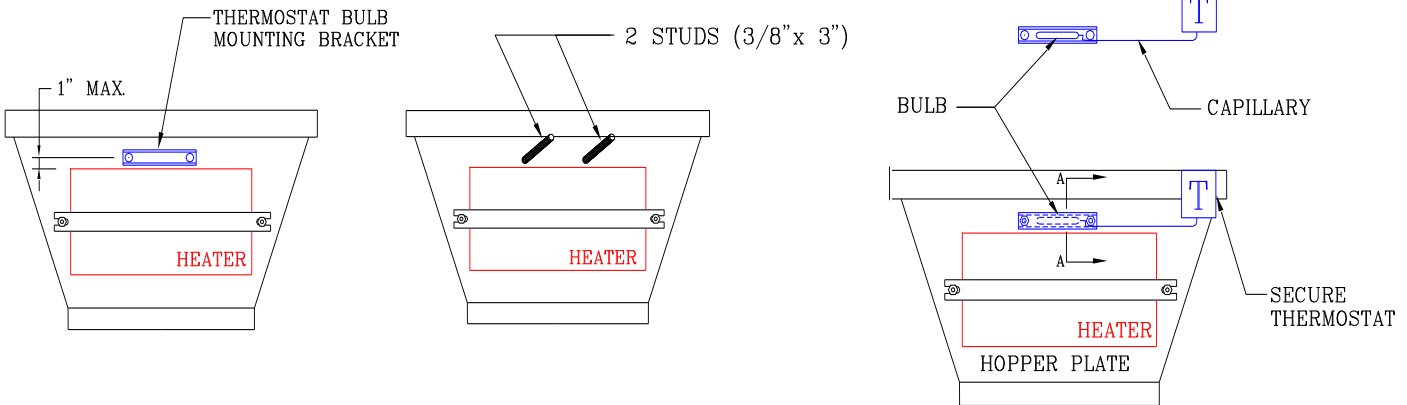

THERMOSTAT BULB SENSOR INSTALLATION INSTRUCTIONS

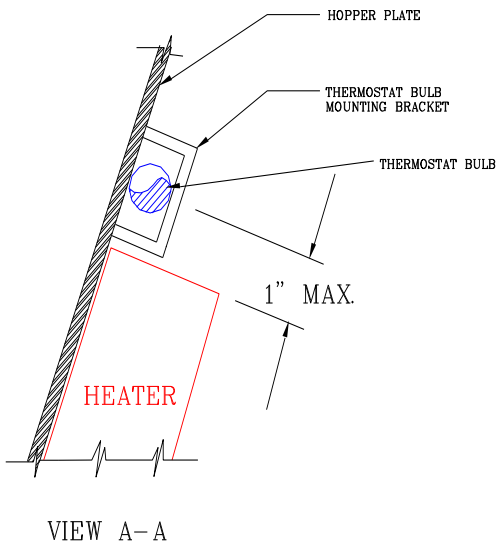

- 1) Identify the temperature sensor location on the hopper per job drawings.
- 2) Place the thermostat bracket in the specified location such that the studs would be located within 1 inch of the heater.
- 3) Mark the two stud locations – same as hole in bracket.
- 4) Weld the studs (3/8" x 3") in the center of the two marked locations. Ensure studs are located perpendicular to plate.
Note: Heater should be removed from hopper during welding of studs to protect it from hot weld spatter.
- 5) Check that the two studs align with the two holes in the thermostat bracket.
- 6) Mount thermostat unit outside the hopper insulation but within the length of the capillary on proper supports. Refer to thermostat manufacturer's instructions for thermostat mounting details.
- 7) Route the thermostat capillary to the specified sensor bulb location on the hopper.
- 8) Place the thermostat bulb inside the bracket with its capillary exiting at one end.
- 9) Place thermostat bracket over the two studs & push it down until its flanges and thermostat bulb contact the hopper plate. (Ensure that the thermostat capillary is not pinched by the bracket flanges.)
- 10) Secure the bracket in place with a washer and nut, then lock it with a second jam nut at each end.
- 11) Ensure that the thermostat bulb is secured and in good, direct contact with hopper plate.
- 12) Secure the thermostat capillary wherever possible and protect it from rubbing against sharp metal surfaces.

SCALE: N.T.S.		BY: J. J. J.		HOTFOIL, INC. ROCKY HILL, CT 06865	
DRAWN: M.J.R. 2/10/98		CHKD: M.J.R. 2/10/98		hotfoil Electric Heat Tracing	
1 REDRAWN ON CAD		M.J.R. 2/10/98		THERMOSTAT BULB SENSOR INSTALLATION	
REV. DESCRIPTION DR. DATE		APP'D. DATE		SHEET 1 OF 1 DRAWING NO. B-1504	
REV. DESCRIPTION DR. DATE		APP'D. DATE		TYPICAL	

THIS DRAWING AND ITS CONTENTS ARE THE EXCLUSIVE PROPERTY OF HOTFOIL, INC. AND NO REPRODUCTION, USE OR DISCLOSURE IS AUTHORIZED WITHOUT HOTFOIL CONSENT.

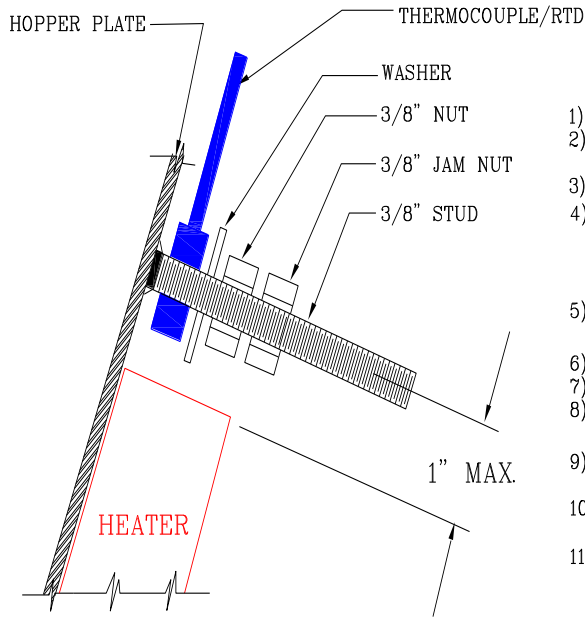
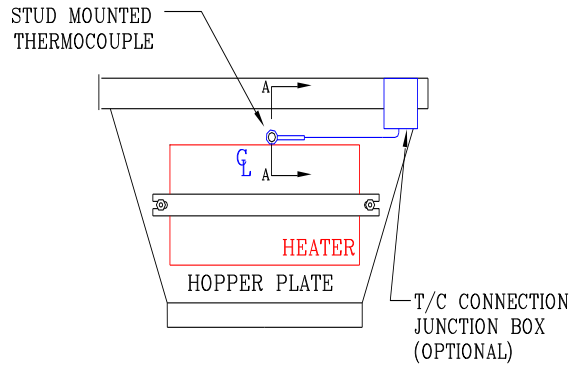
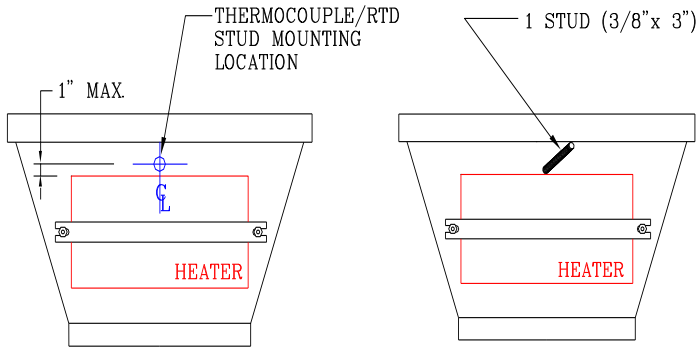

TEMPERATURE SENSOR INSTALLATION INSTRUCTIONS

- 1) Identify the temperature sensor location on the hopper per job drawings.
- 2) Place the stud in the specified location such that the stud would be located within 1 inch of the heater.
- 3) Mark the stud location as shown on the Hopper Drawing
- 4) Weld the stud (3/8" x 3") on the center line of the Heater. Ensure that the stud is located perpendicular to the plate.
Note: Heater should be removed from hopper during the welding of the stud to protect it from hot weld spatter.
- 5) Mount the J.Box (if applicable) outside the hopper insulation but within the length of the lead wires on proper supports.
- 6) Route the thermocouple lead wire to the specified Stud location on the hopper.
- 7) Place the thermocouple over the stud and slide it down.
- 8) Be sure to remove excessive weld build up at the bottom of the stud so that the T/C / RTD Washer must be in full contact with the plate.
- 9) Secure the T/C / RTD in place with a washer and nut, then lock it with a second jam nut.
- 10) Ensure that the T/C /RTD is secured and in good, direct contact with hopper plate.
- 11) Do not run the T/C or the RTD leads near any power wiring.

VIEW A-A

SCALE	N.T.S.	hotfoil Electric Heat Tracing		HOTFOIL, INC. ROBINSHILLE, NEW JERSEY
BY	DATE	DESIGN	DATE	
CHECK	DATE	APP'D.	DATE	
REV.	DESCRIPTION	DR.	DATE	TYPICAL
THERMOCOUPLE / RTD MOUNTING INSTALLATION				SHEET 1 OF 1 DRAWING NO. B-5912

VII - OPERATING INSTRUCTIONS

- 1) The Hotfoil Type HB heating modules are designed for heating flat, metal plate structures in dry non-hazardous locations. It is recommended that all modules/systems be thermally insulated immediately following heater installation. Thermal insulation should be dry and in an undamaged condition. The overall thermal insulation systems should be weather-proofed with an external cladding skin, all seams and joints being sealed.
- 2) Prior to energizing the heaters the following should be completed:
 - a) Check that all heaters to power connections are correct (refer to relevant job schematic).
 - b) Ensure all terminals are clamped properly.
 - c) Ensure all heater cold leads penetrating thermal insulation cannot be damaged
- 3) Each heating system should be controlled separately. This should be achieved using a proper temperature sensor/controller combination. Instrumentation ranging from a local mounted thermostat to remote sensor/electronic controller are acceptable. Only approved instrumentation should be used with an HB module system. If in doubt, contact Hotfoil, Inc.
- 4) Refer to system layout drawings for correct temperature sensor location. Temperature sensor must be held firmly in position, in direct contact with hopper surface. Incorrect installation and/or location can result in poor system performance and excessive power consumption. If in doubt, consult Hotfoil, Inc.
- 5) Temperature control unit should be wired into the entire control/heating system to provide automatic, temperature controller switching of the heaters. Generally, this should be as follows:
 - a) when the temperature at the sensor is BELOW the control set point, heating system should be energized (ON);
 - b) When the temperature at the sensor is ABOVE the set point, systems should be de-energized (OFF). To identify proper controller connections refer to system drawings or manufacturer's installation instructions.
- 6) All temperature controllers have a specific temperature range and maximum operating/exposure temperature. These must not be exceeded or temperature controller may be permanently damaged.
- 7) All temperature controllers have specific electrical current and voltage ratings. These must not be exceeded, since permanent damage to the unit may result causing unsafe or potentially dangerous heating system operation. For applications where total heater electric current or voltage to be switched exceeds the temperature controller ratings, the use of power contactors is required.
- 8) Where due to specific conditions of the application over-heating may result, an override (high temperature limit) temperature controller must be used. Override temperature controller set point must be set at approximately 20°F below the maximum safe temperature.

- 9) In critical applications where control failure may endanger life, limb or property, a backup controller should be used.
- 10) Before heating system is energized, all temperature controllers must be adjusted to appropriate temperature set point, and checked that the automatic temperature control/switching system is operating properly.
- 11) Proper, periodic maintenance program for all electrical components of the heating system, temperature control and power distribution, must be set up and implemented. Refer to specific equipment manufacturer's instructions for recommendations.

VIII - MAINTENANCE INSTRUCTIONS

HB heating modules, once properly installed, are virtually maintenance free. However, to verify that heaters are “electrically sound” a periodic electrical check is recommended.

Frequency of inspections and tests should depend on severity of environment and operating conditions but should be performed at least once a year.

Flexible heaters, like hopper throat, poke tube, manway, extension heaters, etc., once energized should not be removed and reinstalled since permanent damage to that heater may result.

- 1) Check thermal insulation over the heaters for physical damage since heaters beneath it may have been damaged also. Replace entire heating module with cold leads if any part affecting its electrical integrity is damaged.
- 2) If thermal insulation is removed from the hopper/vessel check heaters and wiring for secure mounting, good physical contact or any other abnormalities. Correct problems before re-applying thermal insulation
- 3) Check heater electric continuity and correct DC resistance:
 - a) De-energize heating system.
 - b) Disconnect individual heater from terminal block.
 - c) Measure and record DC resistance with an ohm meter.
 - d) Verify against corresponding job drawings that DC resistance is within +/- 10%.
- 4) Check heater insulation resistance (while the heater is still connected):
 - a) Connect a 500 VDC megohm meter between shorted heater cold leads and the hopper/vessel (ground) on which installed.
 - b) Apply test voltage for 60 seconds.
 - c) Read and record insulation resistance value (50 megohms minimum).
 - d) Reduced values may indicate excessive moisture present within the heater and should be dried out before re-energizing (refer to section on “Heater Dry Out Procedure”).
- 5) Check all wiring for correct and tight interconnections.
- 6) Check all thermal insulation, cladding, cladding seals and joints to ensure weatherproof integrity.

IX HEATER DRY OUT PROCEDURE

Insulation Resistance	Item	Heater	Dry Out Procedure
Greater than 50 Megohms	1	Not Installed	None
	2	Installed	None
1.0 to 50 Megohms	3	Not Installed	A) Energize with $\frac{1}{4}$ of the rated voltage for 24 hours. Heaters should be wired in series where applicable- check Hotfoil drawings. B) Recheck insulation resistance. If no improvement, contact Hotfoil, Inc.
	4	Installed	A) Energize with rated voltage for 12 hours. Heaters should be wired in series where applicable- check Hotfoil drawings. B) Recheck insulation resistance. If no improvement, contact Hotfoil, Inc.
Less than 1.0 Megohms	5	Not Installed	A) Place in warm/dry environment for 24 hours (or until insulation resistance value exceeds 1.0 megohms). B) When insulation resistance exceeds 1.0 megohms follow steps 3A and 3B.
	6	Installed	A) Remove from hopper and follow steps 5A, 5B, 3A and 3B.

THIS DRAWING AND ITS CONTENTS ARE THE SOLE PROPERTY OF
 HOFFER, INC. AND NO REPRODUCTION, USE OR DISCLOSURE IS AUTHORIZED
 WITHOUT WRITTEN CONSENT.

SUGGESTED METHOD OF ROUTING COLD LEADS

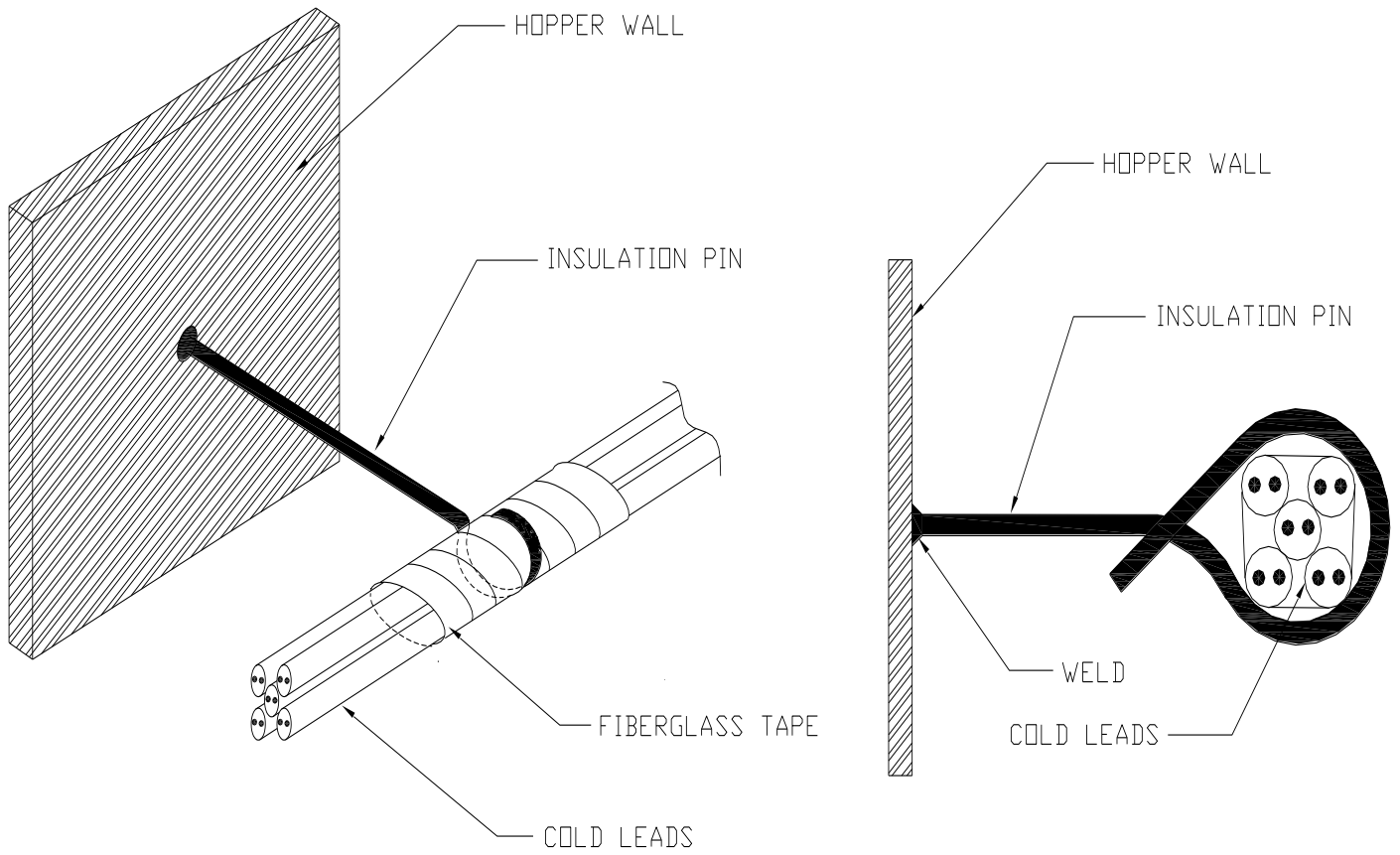

7" INSULATION PIN
 RECOMMENDED

SCALE	N.T.S.	BY	DATE	h o f f e r
DESIGN	P.J.P.	1/20/99		
CHECK				
APP'D.				
JOB NO.	TYPICAL			
COLD LEAD ROUTING				SHEET 1 OF 1
DRAWING NO. A-1073				REV. 0